

County of Lehigh Online Records Access
Property Details

Street View

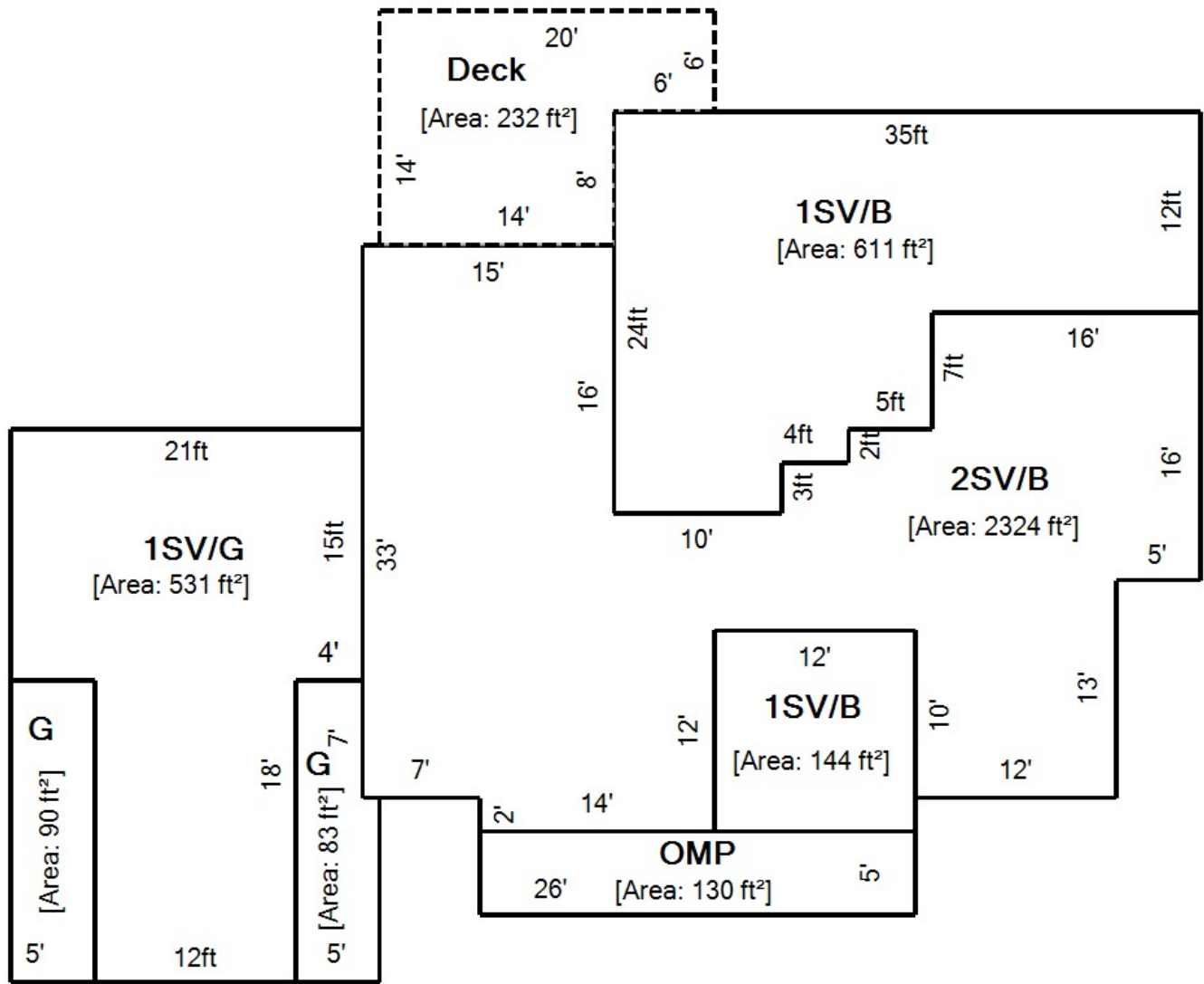



Property Overview

| | 2026 | | |
|------------------------------|--|-----------|------------------------|
| Owner Name | MUELLER LANCE & JESSICA | | |
| Owner Address | 9345 MERLOT CIR BREINIGSVILLE PA 18031-1849 | | |
| Property Address | 9345 MERLOT CIR BREINIGSVILLE PA 18031 | | |
| Parcel Viewer | View in Parcel Viewer | | |
| Low Number | 9345 | | |
| High Number | 9345 | | |
| Sub Division | THE VINEYARD | | |
| Tax Authority | UPPER MACUNGIE TOWNSHIP | | |
| School District | PARKLAND SCHOOL DISTRICT | | |
| Parcel Id | 545438662835 1 | | |
| Old Parcel Id | 20 | | |
| Tile | 445502 | | |
| Acres/Dimension | 149.53 X 257.53 IRREG | | |
| Lot Sq Ft | 42187 | | |
| Utilities | PUBLIC WATER | | |
| Class | RESIDENTIAL | | |
| Land Use | SINGLE FAMILY - DETACHED | | |
| Living Units | 1 | | |
| Zoning | R1 | | |
| Homestead Act 72 | You may apply if it is your permanent primary residence. | | |
| Preferential Land Act | NO | | |
| Agricultural Easement | NO | | |
| Assessment Base Year | 2013 | | |
| Total Assessment | | | |
| | Exempt Land | | 0 |
| | Exempt Building | | 0 |
| | Taxable Land | | 73,100 |
| | Taxable Building | | 357,600 |
| | Total | | 430,700 |
| | Taxable Total | | 430,700 |
| Estimated Taxes | Mills | | Estimated Taxes |
| | County | 3.780000 | \$ 1,628.05 |
| | School | 17.900000 | \$ 7,709.53 |
| | Municipality | 0.640000 | \$ 275.65 |
| | Total | | \$ 9,613.23 |
| Bill Number | 2006345 | | |
| LC_PropertyAddress | 9345 MERLOT CIR BREINIGSVILLE PA 18031 | | |

Basic Residential Profile

| | |
|--------------------------|--------------------------|
| Type of Residence | SINGLE FAMILY - DETACHED |
| Number of Stories | 2 STORY |

| | |
|---------------------------------|--------------------------|
| Type of Construction | ALUMINIUM/VINYL |
| Type of Basement | FULL |
| Type of Heating/Cooling | CENTRAL AIR |
| Type of Garage | ATTACHED TWO CAR OR MORE |
| Number of Full Bathrooms | 2 |
| Number of Half Bathrooms | 1 |
| Fireplaces | 1 |
| Square Feet | 3610 |
| Year Built | 2006 |
| Pool | NO POOL |
| Implement Buildings | NO IMPLEMENT BLDG |

Residential Profile Data With No Influence on Assessment Value

| | |
|---------------------------|---|
| Total Rooms | 9 |
| Number of Bedrooms | 4 |
| Family Rooms | 1 |

Sales History

| Sale Date | Owner Name | Document Id | Sale Price |
|----------------|-------------------------|-------------|--------------|
| 03/2021 | MUELLER LANCE & JESSICA | 2021014486 | \$ 552,000 |
| 04/2005 | CASTLE HOLDINGS INC | 7257866 | \$ 2,002,000 |
| /0000 | NEW PARCEL | 0000000 | \$ 0 |

The building sketch represents the actual exterior measurement of the structure as measured from the outside. The sketch will show any attached areas and will be labeled with a descriptive code. Measurements are rounded to the nearest foot. Certain sketch dimensions and angles are drawn in approximation to their actual measurements.

The total square-foot area includes only the assessed living area of a residential structure, generally areas that are heated and/or cooled. Living area does not include porches, decks, patios, or garages.

Some of the common abbreviations are listed below for reference:

| BUILDING STYLE | |
|----------------|-------------|
| CODE | DESCRIPTION |
| 1S | 1 STORY |
| 1.5S | 1½ STORY |
| 2S | 2 STORY |
| 2.5S | 2½ STORY |
| 3S | 3 STORY |
| 3.5S | 3½ STORY |
| B-L | BI-LEVEL |
| S-L | SPLIT-LEVEL |

| EXTERIOR | |
|----------|-------------------|
| CODE | DESCRIPTION |
| AV, A, V | ALUMINUM OR VINYL |
| B | BRICK |
| B&F | BRICK & FRAME |
| BFR | BRICK FRONT |
| BTR | BRICK TRIM |
| C | CONCRETE |
| CB | CONCRETE BLOCK |
| F, FR | FRAME |
| ST | STONE |
| SD | STUCCO OR DRYVIT |
| MTL | METAL |
| GL | GLASS |

| CODE | DESCRIPTION | CODE | DESCRIPTION |
|------|------------------------|-------|---------------------|
| A | ATTIC | IGP | INGROUND POOL |
| BAL | BALCONY | LD | LOADING DOCK |
| B | BASEMENT | MP | MASONRY PATIO |
| BAY | BAY | MS | MASONRY SLAB |
| BSG | BASEMENT GARAGE | NB | NO BASEMENT |
| BW | BREEZEWAY | NA | NOT ADDED |
| BLT | BUILT | NI | NOT INCLUDED |
| CP | CARPORT | OFP | OPEN FRAME PORCH |
| CPY | CANOPY | OMP | OPEN MASONRY PORCH |
| CC | CATHEDRAL CEILING | OH | OVERHANG |
| CRLS | CRAWL SPACE | PB | PART BASEMENT |
| DECK | DECK | PW | PARTY WALL |
| EFP | ENCLOSED FRAME PORCH | RECRM | RECREATION ROOM |
| EMP | ENCLOSED MASONRY PORCH | S | SHED |
| FB | FINISHED BASEMENT | SQFT | SQUARE FOOT |
| FDN | FOUNDATION | STRG | STORAGE |
| G | GARAGE | UFB | UNFINISHED BASEMENT |
| GH | GREENHOUSE | WD | DECK |

EXAMPLE SKETCH

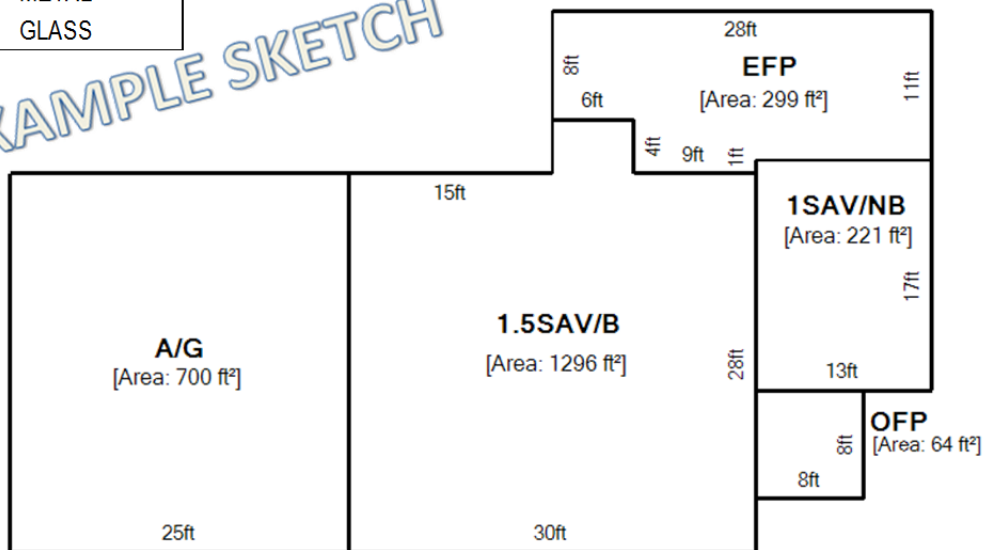

Information on this site is used for tax assessment purposes only and is subject to change without prior notice. The County of Lehigh Assessment Office assumes no responsibility for the use of the information for any other purpose. The use of information for any other purpose other than for tax assessment purposes is the sole and exclusive responsibility of the individual or entity using the information.